

2082

Underground Utilities Locator

Users Manual

LIMITED WARRANTY AND LIMITATION OF LIABILITY

Each Fluke product is warranted to be free from defects in material and workmanship under normal use and service. The warranty period is two years and begins on the date of shipment. Parts, product repairs, and services are warranted for 90 days. This warranty extends only to the original buyer or end-user customer of a Fluke authorized reseller, and does not apply to fuses, disposable batteries, or to any product which, in Fluke's opinion, has been misused, altered, neglected, contaminated, or damaged by accident or abnormal conditions of operation or handling. Fluke warrants that software will operate substantially in accordance with its functional specifications for 90 days and that it has been properly recorded on nondefective media. Fluke does not warrant that software will be error free or operate without interruption.

Fluke authorized resellers shall extend this warranty on new and unused products to end-user customers only but have no authority to extend a greater or different warranty on behalf of Fluke. Warranty support is available only if product is purchased through a Fluke authorized sales outlet or Buyer has paid the applicable international price. Fluke reserves the right to invoice Buyer for importation costs of repair/replacement parts when product purchased in one country is submitted for repair in another country.

Fluke's warranty obligation is limited, at Fluke's option, to refund of the purchase price, free of charge repair, or replacement of a defective product which is returned to a Fluke authorized service center within the warranty period. To obtain warranty service, contact your nearest Fluke authorized service center to obtain return authorization information, then send the product to that service center, with a description of the difficulty, postage and insurance prepaid (FOB Destination). Fluke assumes no risk for damage in transit. Following warranty repair, the product will be returned to Buyer, transportation prepaid (FOB Destination). If Fluke determines that failure was caused by neglect, misuse, contamination, alteration, accident, or abnormal condition of operation or handling, including overvoltage failures caused by use outside the product's specified rating, or normal wear and tear of mechanical components, Fluke will provide an estimate of repair costs and obtain authorization before commencing the work. Following repair, the product will be returned to the Buyer transportation prepaid and the Buyer will be billed for the repair and return transportation charges (FOB Shipping Point).

THIS WARRANTY IS BUYER'S SOLE AND EXCLUSIVE REMEDY AND IS IN LIEU OF ALL OTHER WARRANTIES, EXPRESS OR IMPLIED, INCLUDING BUT NOT LIMITED TO ANY IMPLIED WARRANTY OF MERCHANTABILITY OR FITNESS FOR A PARTICULAR PURPOSE. FLUKE SHALL NOT BE LIABLE FOR ANY SPECIAL, INDIRECT, INCIDENTAL OR CONSEQUENTIAL DAMAGES OR LOSSES, INCLUDING LOSS OF DATA, ARISING FROM ANY CAUSE OR THEORY.

Since some countries or states do not allow limitation of the term of an implied warranty, or exclusion or limitation of incidental or consequential damages, the limitations and exclusions of this warranty may not apply to every buyer. If any provision of this Warranty is held invalid or unenforceable by a court or other decision-maker of competent jurisdiction, such holding will not affect the validity or enforceability of any other provision.

Fluke Corporation
6920 Seaway Blvd.
Everett, WA 98203
U.S.A.

Fluke Europe B.V
PO Box 1186
5602 BD EINDHOVEN
The Netherlands

Table of Contents

	Title	Page
Introduction		1
Contact Fluke		1
Safety Information		2
Specifications		2
Radio Frequency Data.....		2
Before You Start		2
Receiver Controls and Display		3
Receiver Controls.....		3
Receiver Display		4
Left-Right Arrows.....		5
Receiver Setup		5
Antenna Configurationss.....		6
Using the Peak Mode.....		6
Using the Null Mode.....		7
Receiver Alerts		8
Screen Alerts.....		8
Depth Measurement Related Alerts.....		8
Wireless setup (2082BTR only).....		9
GPS (Global Positioning System) / GNSS (Global Navigation Satellite System).....		9
Transmitter Controls and Display		10
Transmitter Controls.....		10
Transmitter Display		11
Transmitter Settings Menu Functions		12
Signal Clamp		13
Main Applications.....		14
General Tracing Techniques for All Applications		14
Receiver Locating		14

Power Mode 50/60 Hz – Passive Location of Energized Cables and Power Lines	16
Radio Mode – Passive Location of Utilities	16
Induction Mode – Locating Utilities	17
Induction Mode – Setting Up the Transmitter.....	17
Induction Mode – Locating with the Receiver	18
Direct Test Leads Connection Mode – Tracing an Individual Pipe or Cable	19
Direct Test Leads Connection Mode – Setting Up the Transmitter	21
Direct Test Leads Connection Mode – Locating with the Receiver	22
Signal Clamp Accessory – Tracing an Individual Pipe or Cable.....	22
Signal Clamp Accessory – Setting Up the Transmitter.....	23
Signal Clamp Accessory – Locating with the Receiver	23
Special Applications.....	24
When to Use 8 kHz vs. 33 kHz Frequency	24
Locating Non-Metallic Pipes and Sewer Lines.....	24
Taking Depth and Current Measurements	24
Checking for depth errors due to signal distortion.....	26
Voltage, Resistance and Output Current Measurements Using the Transmitter ...	26
Advanced Locating Techniques – Two Person Swap	26
Locating Faults with the AF2082 A-Frame Accessory.....	27
Maintenance	28
Battery Replacement.....	28
Fuse Replacement.....	29
Product Disposal	30

Introduction

The Fluke 2082 Underground Utilities Locator (the Product or Tester) is a battery-powered device designed to detect and trace underground electrical cables and utilities lines.

The Product uses signal detection techniques to accurately identify the underground utilities and provides precise depth and position readings to prevent accidental cable damage.

The Product consists of:

- The Transmitter injects a traceable signal onto an underground cable.
- The Receiver detects the signal that is injected by the transmitter and pinpoints the location and depth of the cable.
- The accessory signal clamp enables the Transmitter to induce the locate signal through the insulation onto the cable.
- The A-Frame is used in combination with the Transmitter to identify the cable ground fault.

Contact Fluke

Fluke Corporation operates worldwide. For local contact information, go to our website:

www.fluke.com.

To register your product, view, print, or download the latest manual or manual supplement, go to our website.

+1-425-446-5500

fluke-info@fluke.com

Safety Information

General Safety Information is in the printed Safety Information document that ships with the Product and at www.fluke.com. More specific safety information is listed where applicable.

A **Warning** identifies conditions and procedures that are dangerous to the user. A **Caution** identifies conditions and procedures that can cause damage to the Product or the equipment under test.

Specifications

Complete specifications are at www.fluke.com. See the 2082 Product Specifications.

Radio Frequency Data

Note

Changes or modifications to the wireless 2.4 GHz radio not expressly approved by Fluke Corporation could void the user's authority to operate the equipment.

For complete information about radio frequency data, go to www.fluke.com/manuals and search for "Radio Frequency Data Class A".

The radio certification for a specific region is viewable on the Tester.

To view the radio certification labels, see the decal inside the battery compartment.

Before You Start

Table 1 is a list of items included with the Product. Use the model numbers to order additional components.

Table 1. Standard Equipment

Item	2082	2082BT	2082BT-P	Part Number
2082T Transmitter	●	●	●	--
2082R Receiver	●		●	--
2082BTR Receiver		●	●	--
C2082 Carrying Case	●	●	●	6074065
TL2082 Test Lead Kit	●	●	●	6074020
SC2082 Signal Clamp			●	6074054
MH2082 Paint Marker Holder			●	--
FLG2082 Marking flags, 8 colors, 100 pcs	●	●	●	--
FP-UAT-600 Fuse, 2-pack	●	●	●	4994468
Battery LR6, AA x 6	●	●	●	--
Battery LR20, D-cell x 8	●	●	●	--

Table 2. Optional Accessories

Model Number	Description	Part Number
SC2082	Signal clamp	6074054
AF2082	A-Frame cable ground fault locator	6074031
TL-600-25M	25 meter test lead extension set	5039614
FP-UAT-600	Fuse, 2-pack	4994468

Receiver Controls and Display

Receiver Controls

Table 3. Controls

Item	Description	Item	Description
1	Light Sensor	2	LCD Display (high-contrast, sunlight-optimized)
3	Keypad	4	Speaker

Item	Description								
5	Battery Compartment								
6	Power On/Off (ⓘ) : push for 2 seconds to turn the Receiver ON/OFF.								
7	Volume/Depth (🔊) : <ul style="list-style-type: none"> • Volume – Press momentarily to change between mute, low, med and hi volume levels. • Depth Measurement – Press and hold (> 2 seconds) until depth measurement indication appears on the screen. 								
8	+ / - : displays sensitivity adjustment on the main screen and for up/down selection in menu screen.								
9	Hz : Press momentarily to toggle between available frequency options. <table border="1" style="width: 100%; border-collapse: collapse;"> <tr> <td style="padding: 2px;">8 kHz</td> <td style="padding: 2px;">8 kHz Active mode</td> </tr> <tr> <td style="padding: 2px;">33 kHz</td> <td style="padding: 2px;">33 kHz Active mode</td> </tr> <tr> <td style="padding: 2px;">50 Hz / 60 Hz</td> <td style="padding: 2px;">Power mode (50 or 60 Hz)</td> </tr> <tr> <td style="padding: 2px;">Radio</td> <td style="padding: 2px;">Radio mode</td> </tr> </table> <p>Press >2s to enable or disable the wireless (2082BTR only).</p>	8 kHz	8 kHz Active mode	33 kHz	33 kHz Active mode	50 Hz / 60 Hz	Power mode (50 or 60 Hz)	Radio	Radio mode
8 kHz	8 kHz Active mode								
33 kHz	33 kHz Active mode								
50 Hz / 60 Hz	Power mode (50 or 60 Hz)								
Radio	Radio mode								
10	ENTER / MENU : Press momentarily to enter Receiver settings menu.								

Receiver Display

The Receiver display features a high-contrast, sunlight-optimized black and white LCD screen. It also has an auto-backlight feature that activates in dark areas for optimized viewing.

Table 4. Display

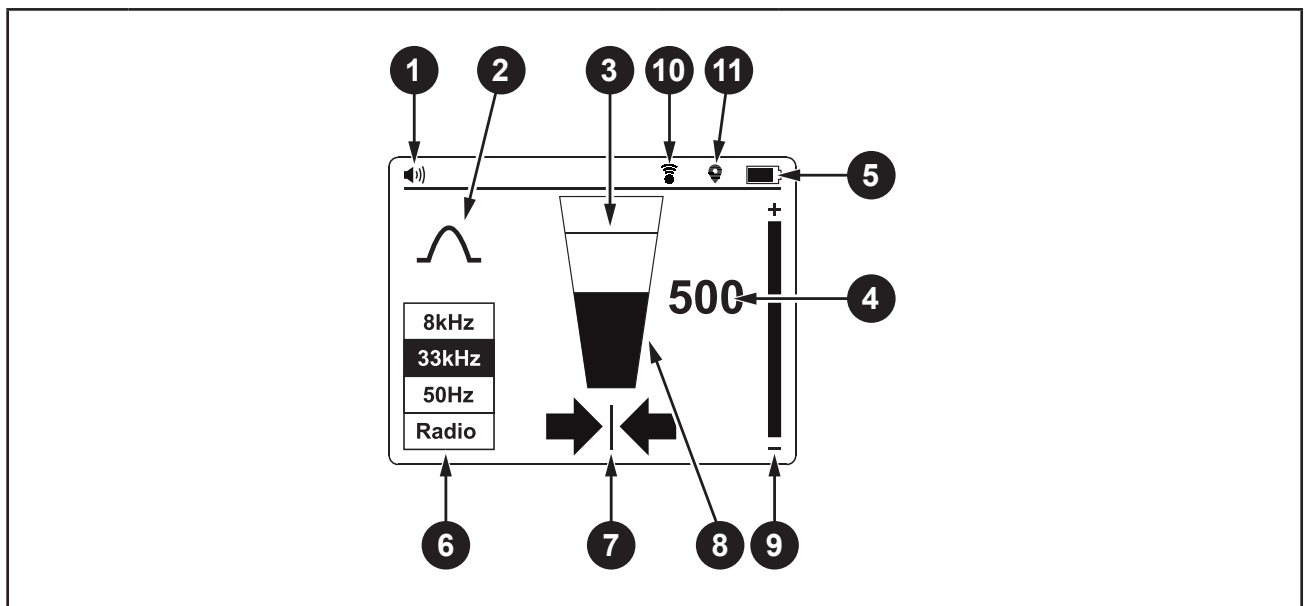

Item	Description	Item	Description
1	Speaker Volume	2	Locate Mode Indicator
3	Signal Level – Peak Indicator	4	Signal Level – Number Display (0-999 relates to 0-99.9%)
5	Battery Status Indicator	6	Signal Locating Frequency
7	Left-Right Arrows	8	Signal Level – Bar Graph
9	Sensitivity Setting Indicator		
10	📶 Shows a solid indication status when a mobile device is connected (2082BTR only)		
11	📍 Shows a solid indication status when GPS connection is established (2082BTR only)		

Left-Right Arrows

These arrows indicate distance from the position of the cable. Both left and right arrows will appear when exactly above the cable.



- ➡ A solid arrow indicates that you are very close to or at the cable location.
- ▣ A heavily shaded arrow indicates that you are approaching the cable location.
- ◀ A lightly shaded arrow indicates that you are far from the cable location.

Receiver Setup

Set-up the Receiver before use, turn on the Receiver and push the **ENTER/MENU** button. The Settings Menu appears..

- Use the **↑** / **↓** buttons to scroll up and down the menu.
- Press **ENTER** to change the setting of a feature.
- To exit, scroll down to **Exit** and press **ENTER**.

From the Settings Menu, it is possible to select:



- Antenna configuration –  Peak or  Null
- Measurements – Imperial (**0 '00"**) or Metric (**0.00 m**)
- Locating frequency for Power Mode – **50 Hz** or **60 Hz**

Note

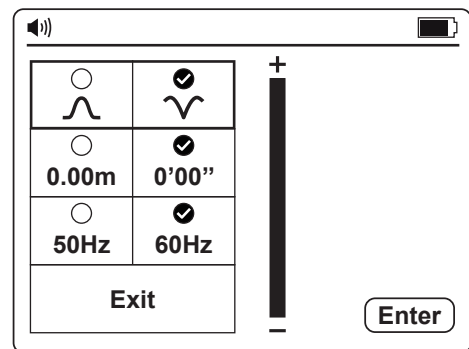
Some selections may not be available in all modes. If not available, the icon will be replaced by a —.



Antenna Configurations

	<p>Peak signal with left/right arrows. This configuration is satisfactory for general purpose locating.</p>
	<p>Null signal with left/right arrows. This configuration gives a sharp Null signal over the line but is less accurate than when in Peak Mode. Is useful for tracing long lines as the sharp Null signal is easy to trace.</p>

Using the Peak Mode

To select Peak Mode, turn on the Receiver and push **ENTER** to access the Settings Menu. Select  and exit the Settings Menu. The bar graph will now show a maximum signal over the line. The left/right arrows will also indicate the position of the line.

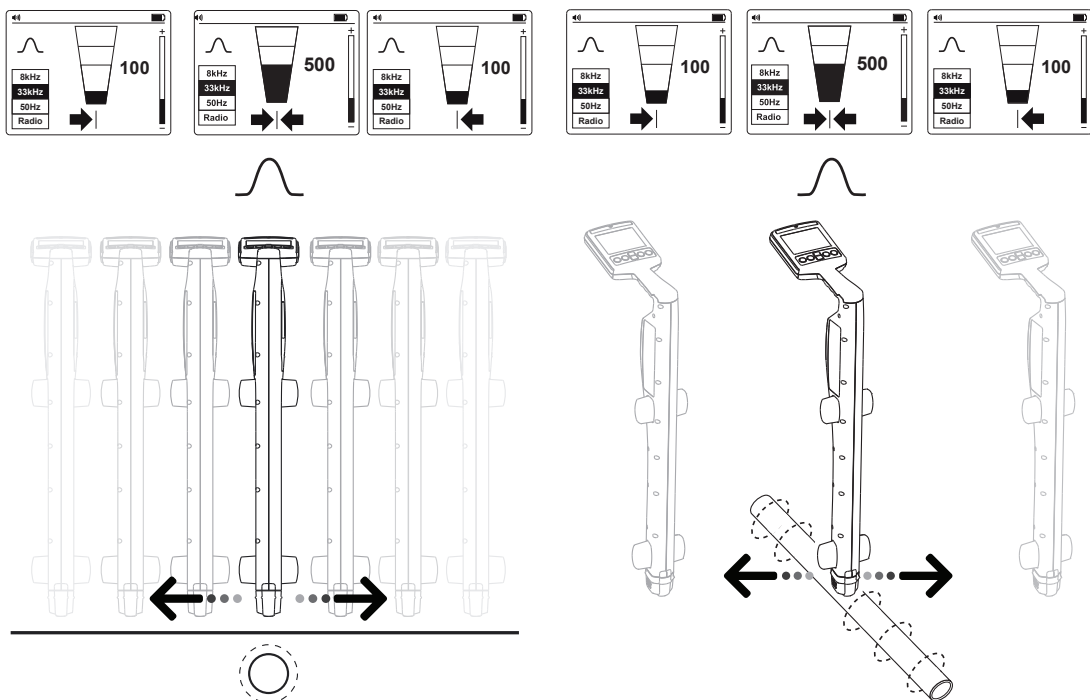

Using the Null Mode

To select Null Mode, turn on the Receiver and push **ENTER** to access the Settings Menu. Select \checkmark and exit the Settings Menu. The bar graph will now show a minimum signal over the line. The left/right arrows will also indicate the position of the line.

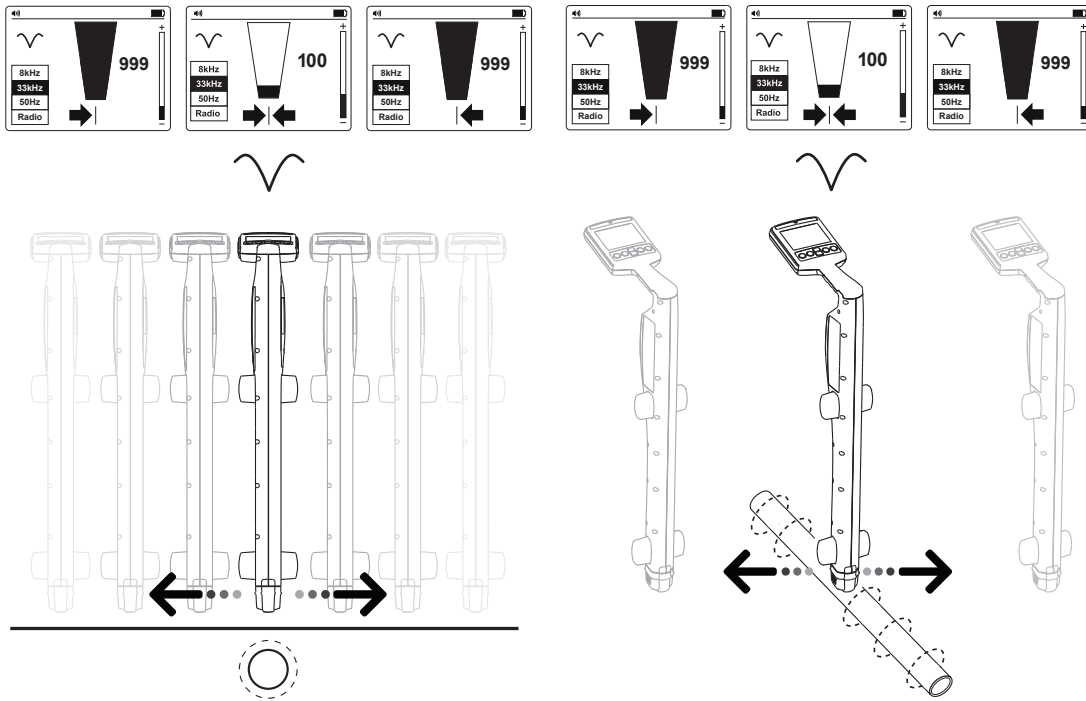





Note

Use the Null Mode with caution as it is not as accurate as Peak Mode. The Null Mode is useful in detecting the approximate position of a line when tracing over a long distance.

Receiver Alerts

Screen Alerts

These alerts appear to the right-hand side of the screen and can appear at any time.

	Indicates that the Receiver is not calibrated. This is usually a factory setting. Service should be contacted.
	Indicates less than 10% battery remaining.
	Indicates that the signal is too large to process correctly. No damage will occur to the electronics, but measurements will be affected. This condition is very unusual.
	When this icon appears the battery voltage is so low that it is not possible to operate the locator. Replace batteries to continue.

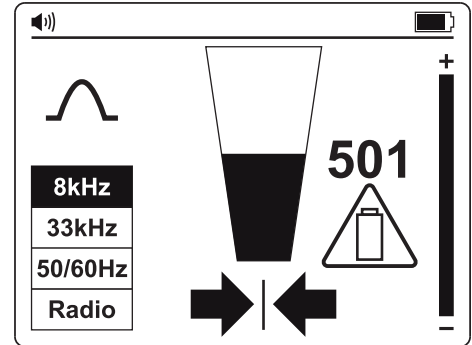



Depth Measurement Related Alerts

These alerts are associated with depth measurements and only appear within the depth pop-up screen section.

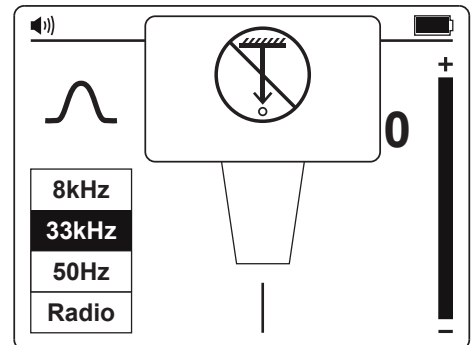
	<ul style="list-style-type: none"> Invalid Depth. Not possible to compute depth. Invalid Depth. Low Signal.
---	---



These alerts appear to the right-hand side of the screen and can appear at any time.

	Signal Overload (Valid depth).
	Overhead Cable (Valid depth).
	Shallow Cable (Valid depth).

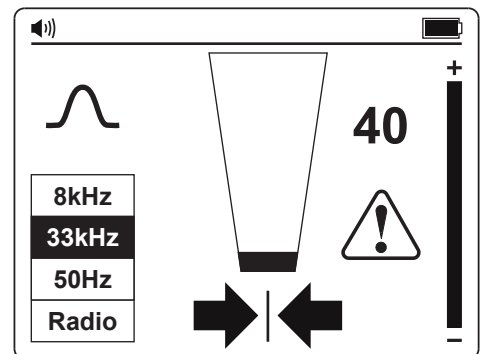

Wireless setup (2082BTR only)

The 2082BTR supports the PointMan mobile application (may not be available in all regions). Use the PointMan app to upload test results from the Product onto your smartphone screen and share these results with your team. You can also download the saved test results to a smartphone and send the data package by email. The PointMan app works with the iPhone and Android Phone. The app is available for download from the Apple App Store and Google Play.

How to enable/disable wireless connection:

On your mobile device

- Enable Bluetooth
- Sign on to the PointMan app and pair your Fluke 2082BTR under Settings.
Note: The wireless on your Fluke 2082BTR must be enabled before scanning for the new device to pair.

On your Fluke 2082BTR:

- Push the **Hz** button >2s to enable the wireless
- The display shows solid "📶" indication when the Product connects to your mobile device.

To turn off the wireless connection on your Product, push **Hz** >2s, 📶 disappears.

GPS (Global Positioning System) / GNSS (Global Navigation Satellite System)

The 2082BTR is equipped with on-board GPS module and the GPS is turned ON upon powering ON the 2082BTR. The GPS icon will turn solid when a valid GPS signal is detected. It can take from a few seconds to a few minutes depending on the environment.

Buildings and dense materials like concrete, steel, and heavy wood can cause the decrease in GPS accuracy by blocking the signals and the effect of multi-path interference. Even with a clear view of sky, these influences can cause inaccurate positioning and unreliable location data.



Transmitter Controls and Display

Transmitter Controls

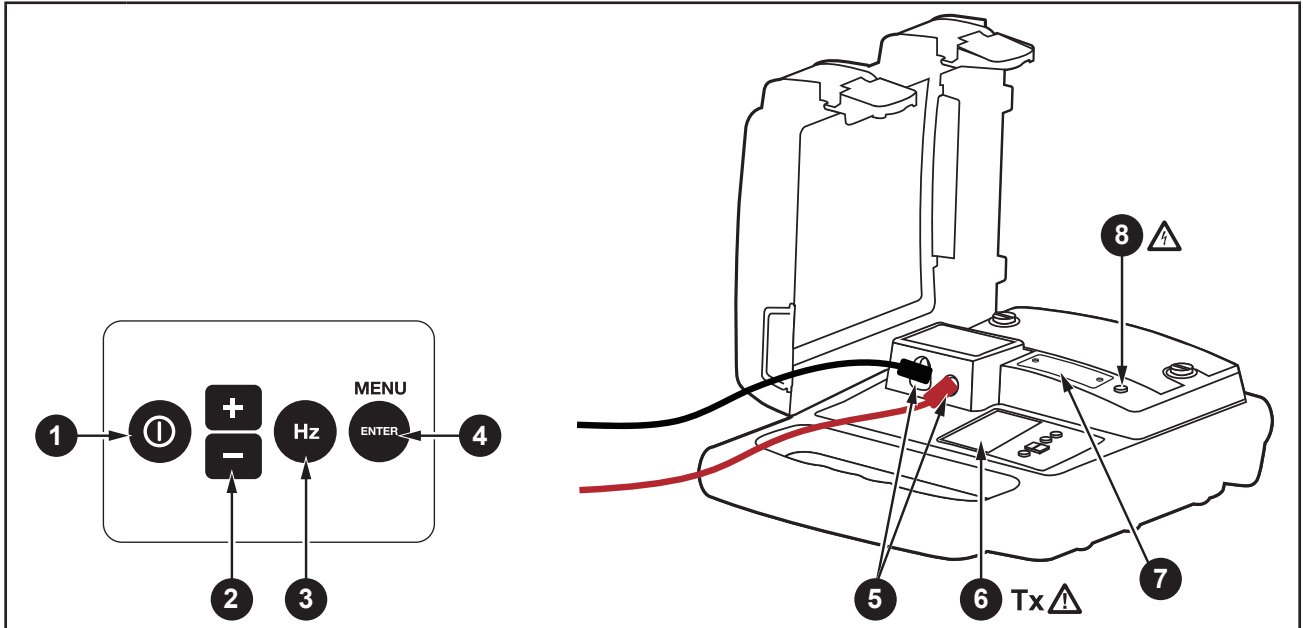
Table 5. Transmitter Controls



Item	Description								
1	Power On/Off (⏻) : press for 2 seconds to turn the Transmitter ON/OFF.								
2	Up/Down (+ / - multifunction buttons) : increase or decrease signal strength on main screen, up/down selection of functions in menu screen; Increase/decreases volume and brightness in submenu screens.								
3	Frequency selection (Hz) : press momentarily to toggle between available frequency options: <table border="1" style="margin-left: 20px;"> <tbody> <tr> <td>8 kHz</td> <td>8 kHz Active mode</td> </tr> <tr> <td>33 kHz</td> <td>33 kHz Active mode</td> </tr> <tr> <td>A-Lo</td> <td>A-Frame mode low signal</td> </tr> <tr> <td>A-Hi</td> <td>A-Frame mode high signal</td> </tr> </tbody> </table>	8 kHz	8 kHz Active mode	33 kHz	33 kHz Active mode	A-Lo	A-Frame mode low signal	A-Hi	A-Frame mode high signal
8 kHz	8 kHz Active mode								
33 kHz	33 kHz Active mode								
A-Lo	A-Frame mode low signal								
A-Hi	A-Frame mode high signal								
4	ENTER / MENU : Press momentarily to enter Transmitter settings menu.								
5	Terminals for direct connection and signal clamp								
6	Tx ⚠ Hazardous output voltage indicator. The icon on the screen indicates the transmitter is outputting voltages ≥ 30 V.								
7	Protection fuse								

Item	Description
8	<p> Hazardous voltage indicator (over 30 V) The red solid light indicates the presence of AC voltage ≥ 30 V on the circuit under direct connection mode. The red blinking light indicates the presence of voltages above 30 V on the Transmitter terminals under A-Lo and A-Hi mode (generated and/or measured). In case of the presence of line voltage >50 V (typical) during the operation of A-Lo or A-Hi mode, the transmitter automatically disables A-Lo and A-Hi modes, the red solid light indicator appears. Always check the presence of voltage on the circuit by additional voltage tester.  Use caution when above voltage indication warnings are ON.</p>

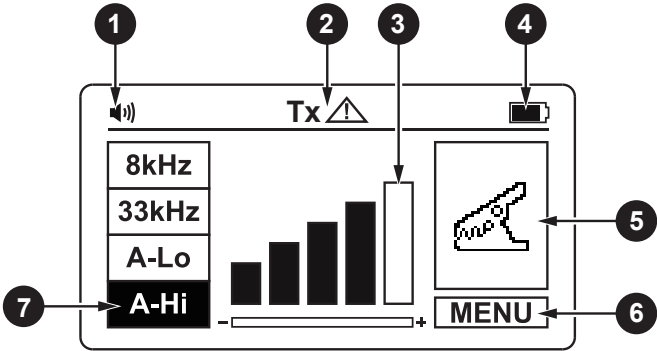

Transmitter Display

Table 6. Transmitter Display

			
Item	Description	Item	Description
1	Speaker Volume	2	Output Hazardous Voltage (over 30 V)
3	Signal Output Level	4	Battery Indicator
5	Locating Mode	6	Menu
7	Frequency Selection		

Transmitter Settings Menu Functions

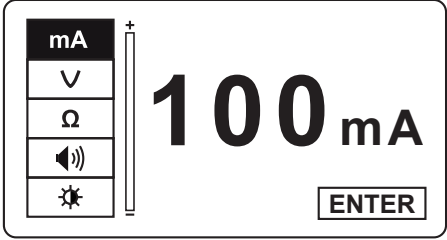
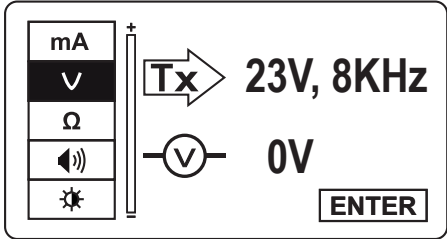
To enter the settings menu, push **ENTER**. Use the \uparrow / \downarrow to scroll up and down through the available options.

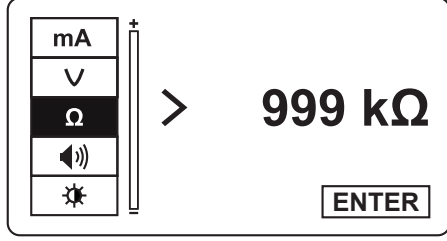
<p>Output Current: This function is only available when test leads are connected. Refer to the Direct Test Leads Connection Mode to properly connect the test leads. The reading indicates a signal output current. If this value is zero, or close to zero, make sure a good connection is made to a target line.</p>	
<p>Voltage Out/In: This function is only available when test leads are connected. Refer to the Direct Test Leads Connection Mode to properly connect the test leads. The top value $\text{Tx} \rightarrow$ indicates the output voltage of the Transmitter and the bottom value V indicates the AC voltage on the line that is connected to the Transmitter.</p> <p>When AC voltage on the line exceeds 600 V (+/- 10%) detected, the transmitter will lock down, turn off the output locate frequency signal, and the screen displays OL until the voltage on the line is removed.</p>	 
<p>Resistance: This function is only available when test leads are connected to de-energized target line. Refer to the Direct Test Leads Connection Mode to properly connect the test leads. The indicated value is the resistance of the line connected to the Transmitter. The maximum measured value is 999 kΩ. The > symbol indicates that the measured value is greater than 999 kΩ.</p> <p>When at A-Lo / A-Hi mode, the ⚠ indicator will blink. In case of a voltage presence ≥ 10 V (typical) on the circuit under test, the Ω measurement will be opt out under MENU screen.</p>	

Speaker Volume: Use \oplus / \ominus to highlight the speaker then push **ENTER**. Use \oplus / \ominus to increase/decrease the volume. Push **ENTER** to exit the speaker menu.

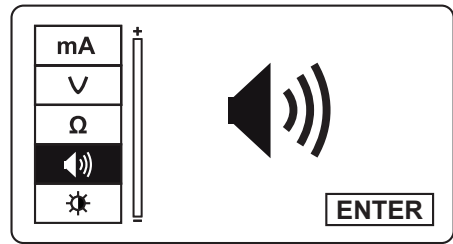

Contrast: Use \oplus / \ominus to highlight the contrast icon then push **ENTER**. Use \oplus / \ominus to increase/decrease the contrast. Push **ENTER** to exit the contrast menu.

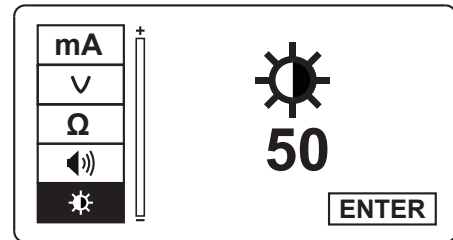

Signal Clamp

In many situations, it is either not possible to gain access to a cable for making an electrical contact or it is not safe to do so. The Signal Clamp accessory provides an efficient and safe method of applying a locate signal to a cable, enabling the Transmitter to induce a signal through the insulation into the wires or pipes. The clamp works on low impedance closed circuits only.

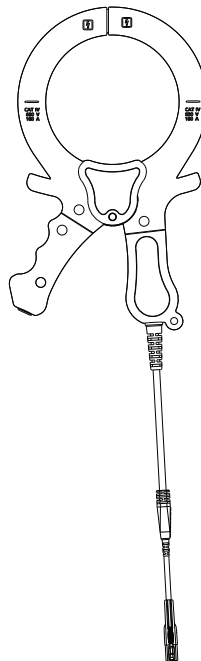

Main Applications

Table 7. Main Applications

Application	Receiver setting	Transmitter Setting	Note
Locating energized 50/60 Hz cables carrying current	Power Mode 50 Hz or 60 Hz	No Transmitter Needed	Receiver will detect signal from any energized 50/60 Hz cable carrying current
Identifying location all metallic utilities: pipes ^[1] , energized and de-energized cables	Radio Mode		Induction Mode
	33 kHz		
Tracing individual pipes ^[1] or cable	8 kHz or 33 kHz	Direct test lead connection ^[2]	Receiver will detect signal only from individual cable/pipe connected to the Transmitter
		Clamp ^[3]	
Fault locating	Use A-Frame	Direct test lead connection, A-Lo or A-Hi	A-Frame will pinpoint the place of the fault

[1] Tracing of non-metallic pipes and conduits is possible after inserting metal fish tape or cable.

[2] Works with energized and de-energized cables.

[3] Works on low impedance closed circuits only.

General Tracing Techniques for All Applications

Receiver Locating

1. Turn on the Receiver, push power button for two seconds. Select the desired locating frequency. Hold the Receiver vertically.
2. Adjust the sensitivity, using the \oplus / \ominus so that the bar graph reading just begins to show some movement. The sensitivity control should be at, or close to, maximum sensitivity.
3. Keeping the Receiver vertical and in front of your body, walk across the area to be checked, then follow in a grid pattern.

Note

Note that there will be no sound from the speaker until the meter reading is above full scale approximately 10%.

Note that objects perpendicular to the receiver will not be detected (white objects in Figure 1). The Receiver will detect objects that are parallel or under angle (gray objects in Figure 1). After performing the initial grid search as shown in drawing A, repeat grid search at 90 degrees as shown in drawing B.

Figure 1. Plan View

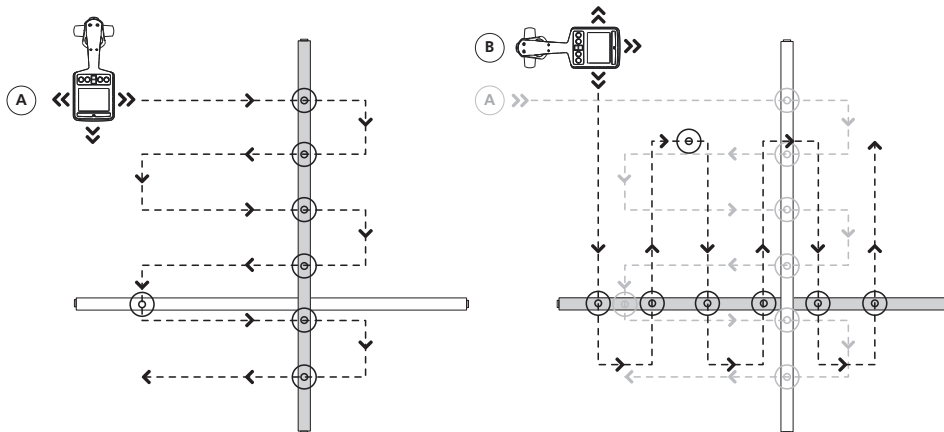

- If at any time the meter reading starts to increase, carefully move the locator forward and back, left to right to detect the maximum signal. Use the bar graph to help confirm the correct position. If the bar graph exceeds the maximum value, adjust the sensitivity to bring the reading back within the limits of the bar graph using \oplus / \ominus .

Note

If the reading is off scale (too great or too small), then pressing the \oplus / \ominus together will automatically adjust the sensitivity to bring the meter deflection to 50%.

- Rotate the Receiver on its axis to obtain the maximum signal. This indicates that the Receiver is directly over the line and aligned with the direction of the cable. The direction can also be verified by rotating until the smallest signal is detected – the Receiver is then perpendicular with the cable/pipe.

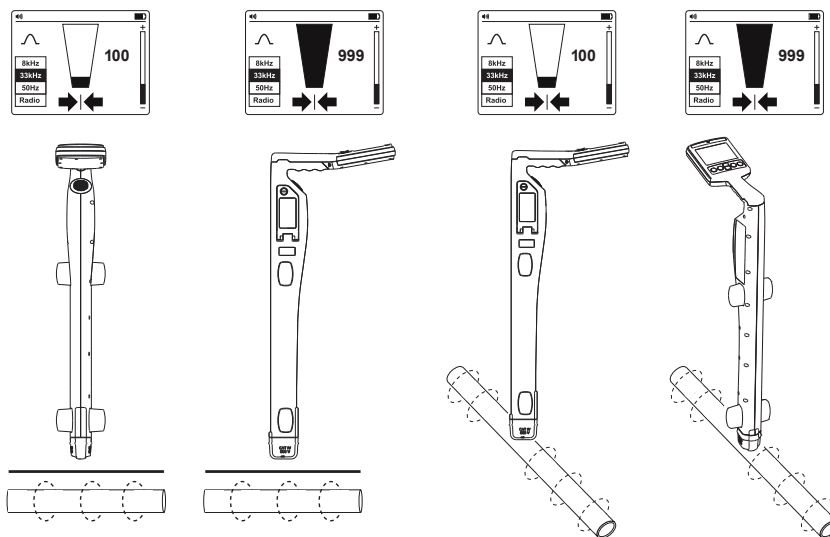

- Walk along the path of the cable and trace it by moving the Receiver left to right to find the highest signal.

Power Mode 50/60 Hz – Passive Location of Energized Cables and Power Lines

Power signals are created by mains power running in the supply cables. These signals are 50 Hz or 60 Hz depending on the region (for example, Europe has 50 Hz power and the United States has 60 Hz power). This frequency can be adjusted on the Receiver.

When electrical power is distributed throughout the network, some of the power finds its way back to the power station via the ground. These stray currents can jump onto pipes and cables and also create power signals.

There must be enough electrical current flowing to create a detectable signal. For instance, a live cable that is not in use may not radiate a detectable signal. A very well balanced cable (exactly the same current flowing in live and neutral) will cancel out and may not create a signal. In practice this is unusual as there are usually enough imbalances in the cable to create a good detectable signal.

1. Turn the Receiver on by pressing the power button for two seconds.
2. Push **H** button repeatedly until the correct frequency is selected. To change frequency between 50 Hz or 60 Hz refer to **Receiver Controls and Display**.
3. Follow the steps as described in the **Receiver Locating**.

Radio Mode – Passive Location of Utilities

Radio signals are created by low frequency radio transmitter and are used for broadcasting and communications. They are positioned throughout the world. As the frequencies are very low, the signals tend to penetrate and hug the curvature of the earth. When the signals cross a long conductor such as a pipe or cable, the signals are re-radiated. It is these re-radiated signals that can be detected by Radio Mode.

Locating radio signals is very similar to detecting power signals as they are both passive. With the Radio Mode method, you will detect metallic utilities, such as pipes, as well as energized and de-energized cables. Tracing of non-metallic pipes and conduits will be possible after inserting metal fish tape or cable.

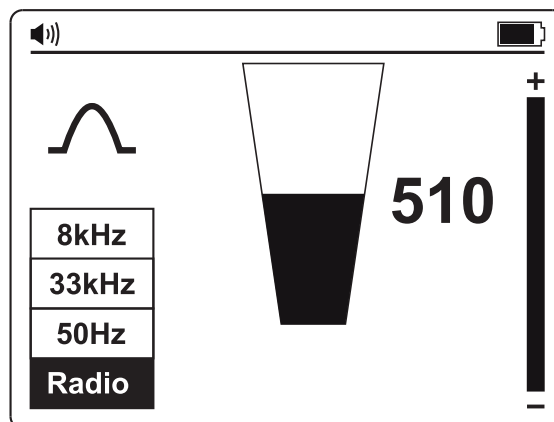

1. Turn on the Receiver, push the power button for two seconds.
2. Push the **Hz** button repeatedly until Radio is selected.
3. Follow the steps as described in the **Receiver Locating**.

Note

The Left/Right arrows are not active during passive location, such as in Power or Radio modes.

Induction Mode – Locating Utilities

Induction Mode is particularly useful for identifying the location of multiple buried utilities before digging. Induction Mode can be also used for tracing individual cables where there is no access to the line to connect test leads or a clamp. However, this method may not be reliable if adjacent lines are present because the signal will be also applied to these lines.

Without the test leads or signal clamp connected to the Transmitter, the Transmitter will automatically start to radiate a signal around it using an internal antenna. These signals will penetrate the ground and couple onto buried lines. The signal will then travel along the line which can be detected with the Receiver.

With the Induction Mode method, you will detect metallic utilities, such as pipes, as well as energized and de-energized cables. Tracing of non-metallic pipes and conduits will be possible after inserting metal fish tape or cable.

Induction Mode – Setting Up the Transmitter

When using Induction Mode, place the Transmitter at least 65 feet (20 m) away from any structure such as building or a tower to avoid signal interference. Before tracing, take a visual inspection of the area looking for clues where the buried utility might be present, such as transformers, manholes, street or parking lamps, etc.

The signal will radiate around the Transmitter as well as below it, so it is recommended that when applying a signal using Induction Mode, a distance of at least 65 feet (20 m) is kept from the Transmitter when pinpointing or taking depth readings. While locating closer than 65 feet is possible, the operator should be aware that the signal directly received from the Transmitter may be strong enough to influence the results.

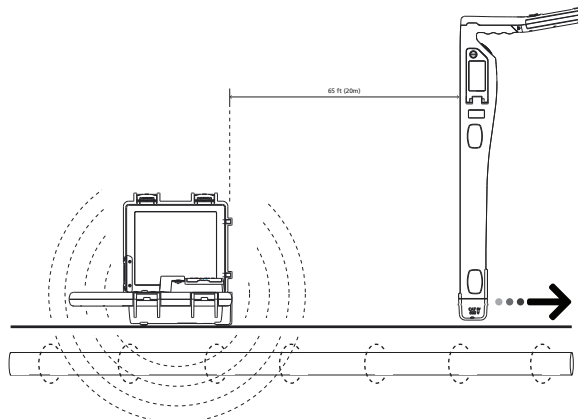

Note

Avoid placing the Transmitter over metallic manhole covers as this will severely reduce the effectiveness of the Transmitter, and in extreme cases, cause damage to the Transmitter's circuitry.

1. Turn on the Transmitter, push the power button for two seconds.
2. Place the Transmitter over the suspected location of the line, positioning it so that it is along the line.

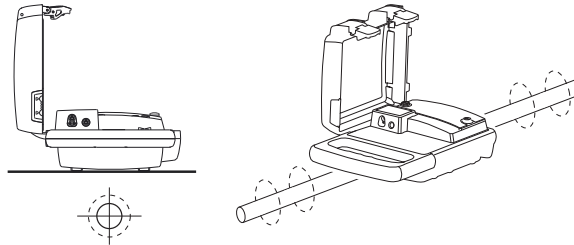

3. Push the \oplus / \ominus to set the output to level one. Increase the level if the resulting signal strength is poor. Increasing the signal unnecessarily may result in the signal being induced into unwanted lines.



Induction Mode – Locating with the Receiver

1. Turn the Receiver on by pressing the power button for two seconds.
2. Push **Hz** button repeatedly until 33 kHz is selected.
3. Follow the steps as described in the **Receiver Locating**, using the Left/Right arrow indicators to quickly assess location of the wire.
4. Optionally measure the depth of the wire. Refer to the **Taking Depth and Current Measurements** for details.

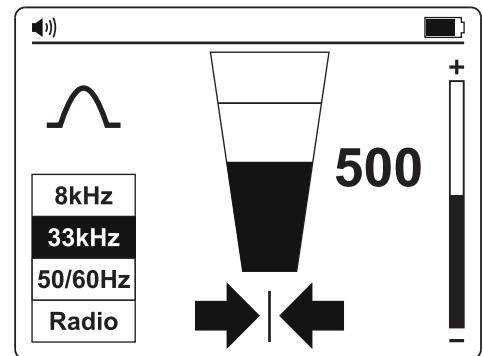

Note

For better accuracy, after the initial location of a utility is detected, move the Transmitter directly over it in case it was not placed precisely in the beginning of the search.

Where the signal is distorted, the arrows may indicate a different target position than the largest bar graph reading. In this situation, always use the bar graph to pinpoint the line as it is influenced less than the Left/Right arrows in a distorted signal field.

Direct Test Leads Connection Mode – Tracing an Individual Pipe or Cable

Direct connection with test leads is the most reliable method to trace individual cable or a pipe.

⚠ Warning

To prevent possible electrical shock, fire, or personal injury:

- Only authorized personnel should make connections to cables.
- The Transmitter can be connected to energized wires up to CAT IV 600 V and any de-energized wire or pipe.
- Do not touch metal parts of the connection clips when connecting to the line or when the Transmitter is on as they may exceed 30 V rms.
- For shielded cables, always connect to the sheath of that cable. The sheath will stop the tracing signal if the Transmitter is connected to one of the internal wires.

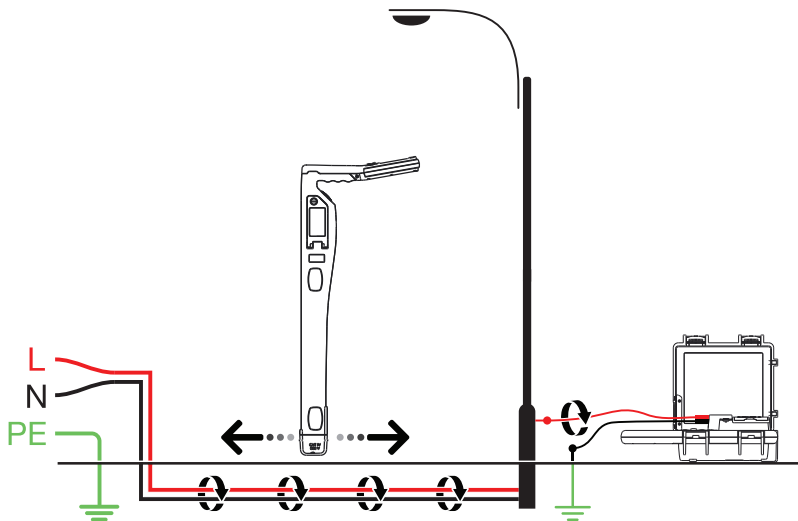

⚠️⚠️ IMPORTANT NOTICE, PLEASE READ BEFORE TRACING

Avoiding signal cancellation problems with a separate ground connection

The signal generated by the Transmitter creates an electromagnetic field around the wire. This field is what is detectable by the Receiver. The clearer this signal, the easier it is to trace the wire.

If Transmitter is connected to two adjacent wires on the same circuit (for example, hot and neutral wires on a Romax cable), the signal travels in one direction through the first wire and then returns (in opposite direction) through the second. This causes the creation of two electromagnetic fields around each wire with opposite direction. These opposing fields will partially or completely cancel each other out, making wire tracing difficult if not impossible.

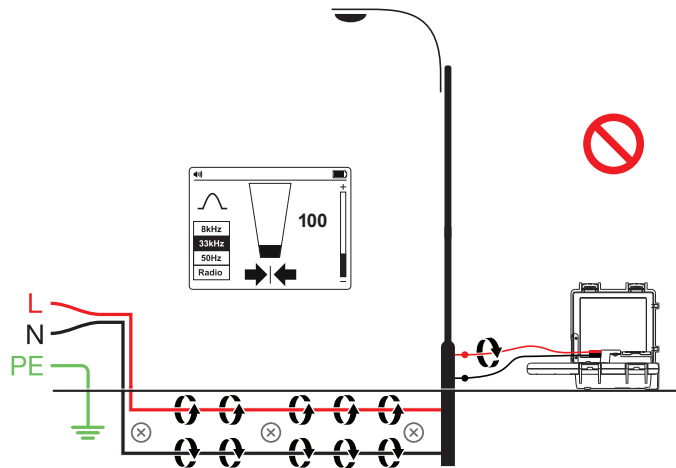

To avoid the cancellation effect, a separate ground connection method should be used. The red test lead of the Transmitter should be connected to the hot wire of the circuit you wish to trace, and the green lead to a separate ground, such as water pipe, ground stake, metal grounded structure of the building, or outlet ground connection of an outlet on a different circuit. It is important to understand that an acceptable separate ground is NOT the grounding terminal of any receptacle on the same circuit as the wire you wish to trace. If hot wire is Energized and the Transmitter is properly connected to a separate ground, the red LED on the Transmitter will light up. The separate ground connection creates maximum signal strength because the electromagnetic field created around the hot wire is not being cancelled by a signal on the return path flowing along an adjacent wire (hot or neutral) in the opposite direction, but rather through the separate ground circuit.

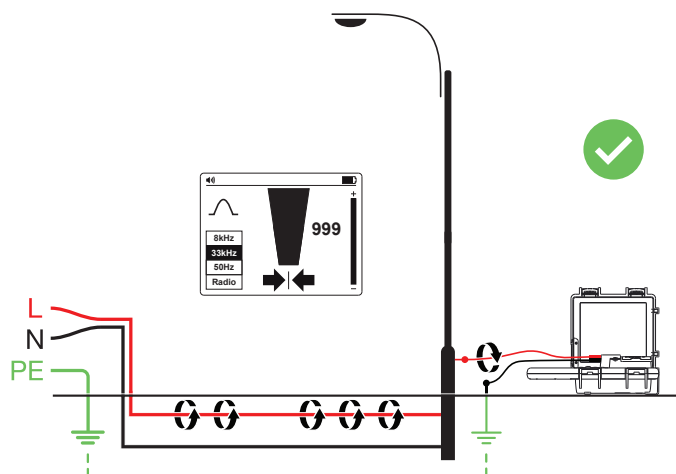

Direct Test Leads Connection Mode – Setting Up the Transmitter

1. Turn on the Transmitter, push the power button for two seconds.
2. Connect the black and red test leads to the Transmitter inputs. The Transmitter will switch automatically to Direct Connection Mode and the display will show the direct connection icon .
3. Insert the ground stake into the ground a few meters perpendicular to the line. Connect the black lead to the ground stake with an alligator clip.
4. Connect the red test lead to the target line. If line is energized above 30 V the red warning LED will illuminate.
5. Push the **Hz** button repeatedly to select 8 kHz frequency (preferred for most tracing situations) or 33 kHz. Refer to [When to Use 8 kHz vs. 33 kHz Frequency](#) for more information. Frequencies A-LO and A-Hi are used with optional A-Frame cable ground fault finder accessory used to pinpoint ground faults and are described later in the manual.
6. Push the \oplus / \ominus to set the output to level one. Increase the level if the resulting signal strength is poor. Increasing the signal unnecessarily can result in the signal “bleeding off” onto other services and creating misleading “ghost” signals. It will also drain more power from the battery.

Note

When connected, the Transmitter will emit a beep tone. The better the connection to the line and ground, the faster the beep tone will be. Check for a good connection by disconnecting and then reconnecting the red lead. You can also check the signal current being supplied by the Transmitter from the Settings Menu by selecting the mA option.

Things that can affect the quality of connection are a rusty pipe connection point (clean the connection area with a wire brush) or poor grounding. To improve the connection quality due to poor grounding, try inserting the stake into damp ground. If necessary, dampen the surrounding ground with water. If grounding is still an issue, try connecting test lead to a manhole cover surround. Avoid connecting to fence railings as these may create return signal currents along the fencing that will interfere with the locating signal.

Note

If the signal level bars do not fill, this indicates that the impedance of the line is limiting the current output. Increasing the output beyond this point will not increase the signal. If more signal is required, check the quality of the connection to the line and ground.

When connecting to large diameter pipes and cables, it is sometimes not possible to find a suitable projection to apply the alligator clip. If the material is ferrous, use a magnet to make contact to the line and then attach the alligator clip to a magnet. For example: making a connection to a street lighting circuit. Usually it is practice to connect the sheath of a lighting cable to the metallic inspection cover of a street lamp. Making a connection to the inspection plate will induce a signal to the cable via the plate and sheath. Usually, there is no projection on the plate on which to clip so using a magnet on the plate provides a suitable clipping point.

Direct Test Leads Connection Mode – Locating with the Receiver

1. Turn on the Receiver, push the power button for two seconds.
2. Match the frequency of the Transmitter by pushing the **Hz** button repeatedly. Select either 8 kHz or 33 kHz depending on the Transmitter setup.
3. Follow the steps as described in the **Receiver Locating**.
4. Use the Left/Right arrow indicators to quickly assess location of the wire.
5. Optionally measure the depth of the wire. Refer to the [Taking Depth and Current Measurements](#) for details.

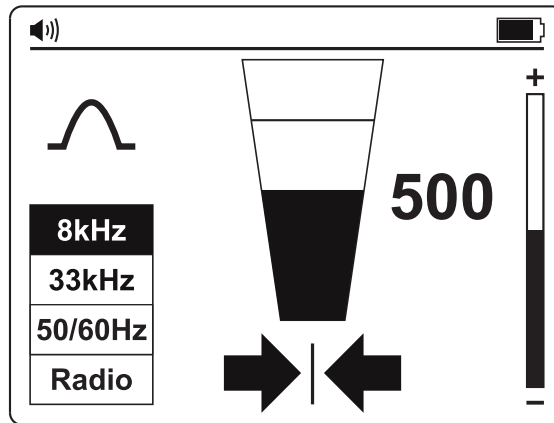

Signal Clamp Accessory – Tracing an Individual Pipe or Cable

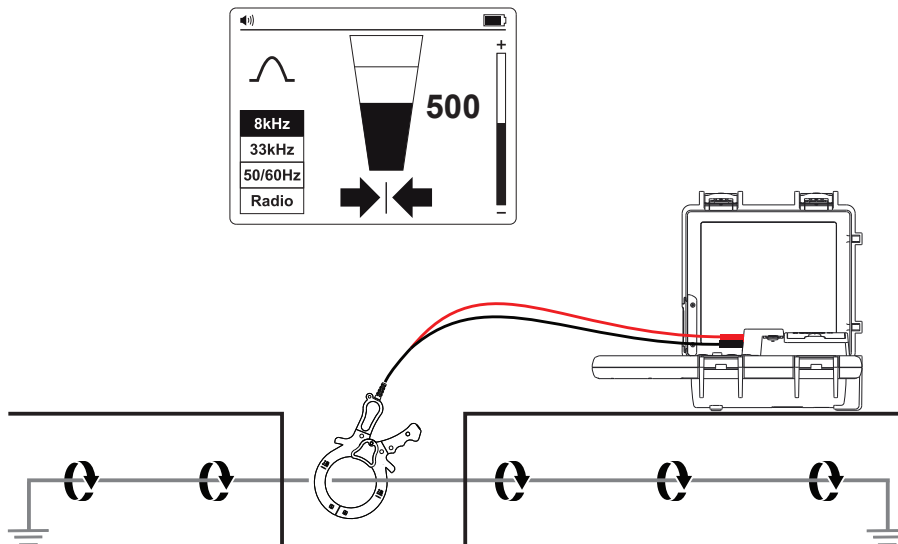

In many situations, it is either not possible to gain access to a cable for making an electrical contact or it is not safe to do so. The Signal Clamp provides an efficient and safe method of applying a locate signal to a cable.

When using the Signal Clamp, it is best if both ends of the target cable are grounded to enable the current to flow. When applying a clamp close to a grounding point where multiple grounds or a grounding bus exists, ensure that the clamp is placed around the target line and not to the ground bus/other grounds to reduce the effects of the transmitted signal also being applied to an unwanted line.

Signal Clamp Accessory – Setting Up the Transmitter

1. Turn on the Transmitter, push the power button for two seconds.
2. Connect the black and red test leads of the Signal Clamp to the Transmitter inputs. The Transmitter will switch automatically to the Clamp Mode and the display will show the clamp icon .
3. Clamp the Signal Clamp around the target line.
4. Push the **Hz** button repeatedly to select 8 kHz frequency (preferred for most tracing situations) or 33 kHz. Refer to [When to Use 8 kHz vs. 33 kHz Frequency](#) for more information. Frequencies A-LO and A-Hi are used for cable sheath ground fault locating and is described later in the manual.
5. Push the \oplus / \ominus to set the output to level one. Increase the level if resulting signal strength is poor. Increasing the signal unnecessarily may result in the signal “bleeding off” onto other services and creating misleading “ghost” signals. It will also drain more power from the battery.

Signal Clamp Accessory – Locating with the Receiver

1. Turn on the Receiver, push the power button for two seconds.
2. Match the frequency of the Transmitter, push **Hz** button repeatedly. Select either 8 kHz or 33 kHz depending on the Transmitter setup.
3. Follow the steps as described in the **Receiver Locating**.
4. Use the Left/Right arrow indicators to quickly assess location of the wire.
5. Optionally measure the depth of the wire. Refer to the [Taking Depth and Current Measurements](#) for details.

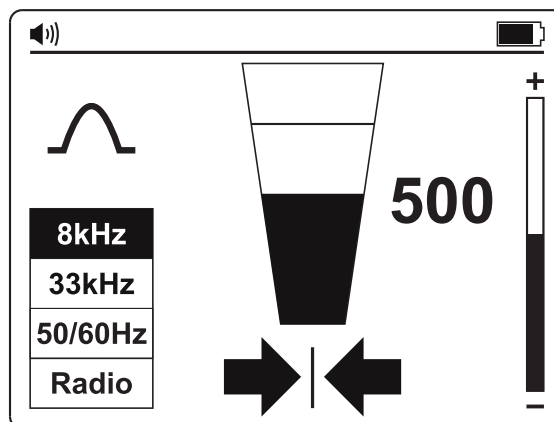

Special Applications

When to Use 8 kHz vs. 33 kHz Frequency

As a general rule, 8 kHz will provide the best compromise between clarity of signal and effects of “bleed off” to other services. However, there are times when the higher 33 kHz frequency is beneficial:

1. Locating pot ended cables: Pot ended cables are generally not grounded. This means that the signal will not readily travel to the pot end. Using a higher frequency will encourage signal current to flow.
2. Small diameter cables: Higher frequencies tend to flow better on small diameter cables, although the rule “first try 8 kHz” still applies.
3. Locating old cast iron pipes: These pipes tend to have mechanical connections between sections which rust over time and prevent an electrical connection between pipe sections. The 33 kHz signal will tend to jump across these joints and continue down the line.
4. Poorly grounded cables: Generally, higher frequencies will travel along a poorly grounded cable better than lower frequencies.

Locating Non-Metallic Pipes and Sewer Lines

The Product can indirectly trace non-metallic conduits and pipes.

1. Insert fish tape or wire inside the conduit or pipe. For sewer lines, use the sewer drain cleaning machine to insert a cleaning cable.
2. Follow steps as described in the **Direct Test Leads Connection Mode – Tracing an Individual Pipe or Cable** Connect the red test lead to the fish tape or the drain cable.

The Receiver will pick up the signal conducted by the fish tape or wire, indicating the location of the non-metallic pipe.

Taking Depth and Current Measurements

Depth and current measurements are only available when the Receiver is set to 8 kHz or 33 kHz frequency. The mode is NOT available in 50/60 Hz or Radio Modes.

To take a depth and current measurement, first pinpoint the position of the line. Place the tip of the Receiver on the ground making sure it is vertical and across the line. Press and hold  until the screen changes to display a dialog box.

The depth measurement can be influenced by several factors including, but not limited to:

- Soil conductivity
- Signal distortion
- Condition of the Product and Batteries

Additional measurement errors can be caused by the environment factors such as soil conductivity and moisture level.

- 2082R screen with valid depth measurement

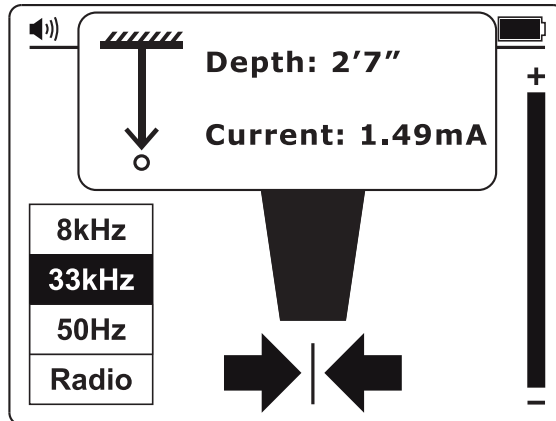

- 2082BTR screen with valid depth and GPS measurement

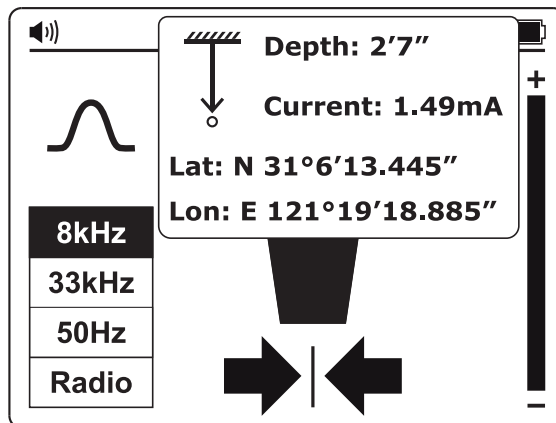

When 2082BTR is connected to mobile application, push **+** button to upload the measurement data to mobile device, or push **-** button to discard the measurement data.

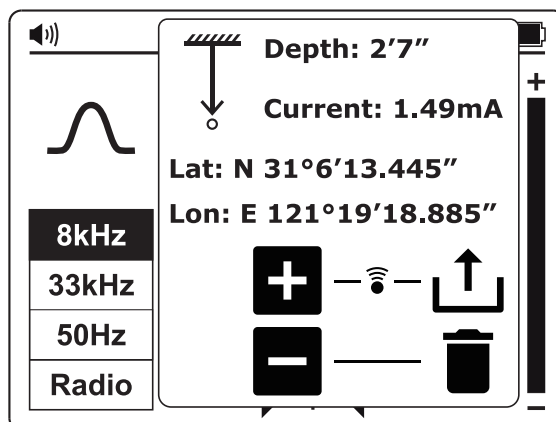

The current measurement feature is useful for confirming that the detected signal is radiating from the traced line. If the signal is “bleeding off” onto other services, the resulting signals will generally be less than that of the originating signal. However, care should be taken as the signal current will gradually reduce over the length of the line. A sudden drop in current over distance indicates that either:

- There is a ground fault on the line which is shunting signal to ground.
- There is a “T” off from the mainline.
- The operator has migrated from the connected line to a line which has some signal that has bled off from the main line.

Checking for depth errors due to signal distortion

One way to determine if the depth measurement is likely to have been affected by distortion is to take a depth reading at ground level, then raise the Receiver a known distance off the ground (such as one foot). Retake the depth reading at the new depth and confirm that the depth has increased by this amount. If the depth has changed by something other than the actual change, then the readings should be treated as suspect.

Distorted signals will cause the located line position to be displaced from the actual position. The errors are more pronounced using the arrows in Null Mode than the Peak Mode bar graph. Hence, if the arrow/null position and peak bar graph position indicate differently, the signal likely distorted and the readings should be treated with caution.

Warnings

To prevent possible electrical shock, fire, or personal injury, never mechanically dig over the path of a buried pipe or cable. Always dig carefully.

Voltage, Resistance and Output Current Measurements Using the Transmitter

Refer to [Transmitter Settings Menu Functions](#) for details.

Advanced Locating Techniques – Two Person Swap

1. Set up the Transmitter as described in the **Induction Mode – Locating Utilities**.
2. Turn on the Receiver, push the power button for two seconds and select 33 kHz frequency by pushing **H_z** button.
3. Select the area to be checked. One person holds the Transmitter with the handle in line with the direction of movement and the other holds the Receiver (as shown below).
4. Stand at least 15 feet (5 m) apart holding the equipment as below, with the Transmitter and Receiver in line with the direction of movement.
5. Adjust the sensitivity of the Receiver so that the meter reads approximately 20% signal strength.

- Walk slowly across the site keeping parallel with each other. As a service is approached, the signal level on the Receiver will increase. When the signal is at a maximum, stop the Transmitter and place it on the ground. Then pinpoint the position of the service with the Receiver as described in the **Receiver Locating**. Mark this position and plot the route across the site if necessary.
- Continue to the sweep across the site and then, if possible, repeat the process at 90 degrees to the sweep already completed.

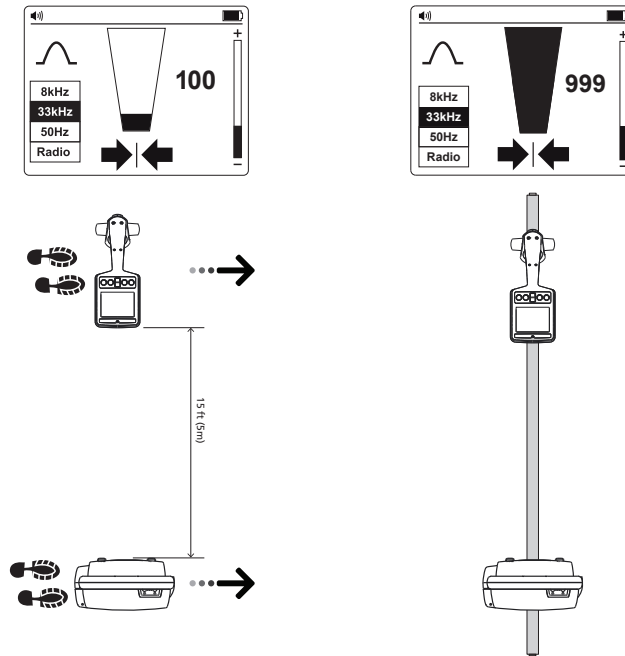

Locating Faults with the AF2082 A-Frame Accessory

The AF2082 A-Frame cable ground fault finder is an optional accessory specifically designed for the Product. In combination with the Transmitter, the A-Frame accessory will pinpoint the place where a cable metal conductor (either a sheath or a metallic conductor of the wire) touches the ground. The A-Frame accessory can also detect other conductors to ground faults such as pipeline coating defects. [Refer to the A-Frame users manual for full instructions.](#)

Maintenance

Periodically wipe the case with a damp cloth and mild detergent. Do not use abrasives or solvents.

Warnings

To prevent possible electrical shock, fire, or personal injury:

- Repair the Product before use if the battery leaks.
- Have an approved technician repair the Product.
- Use only specified replacement parts.
- Replace a blown fuse with exact replacement only for continued protection against arc flash.
- Do not operate the Product with covers removed or the case open. Hazardous voltage exposure is possible.
- Remove the test leads accessory before you clean the Product.

Battery Replacement

Use a flat screw driver to open the battery door.

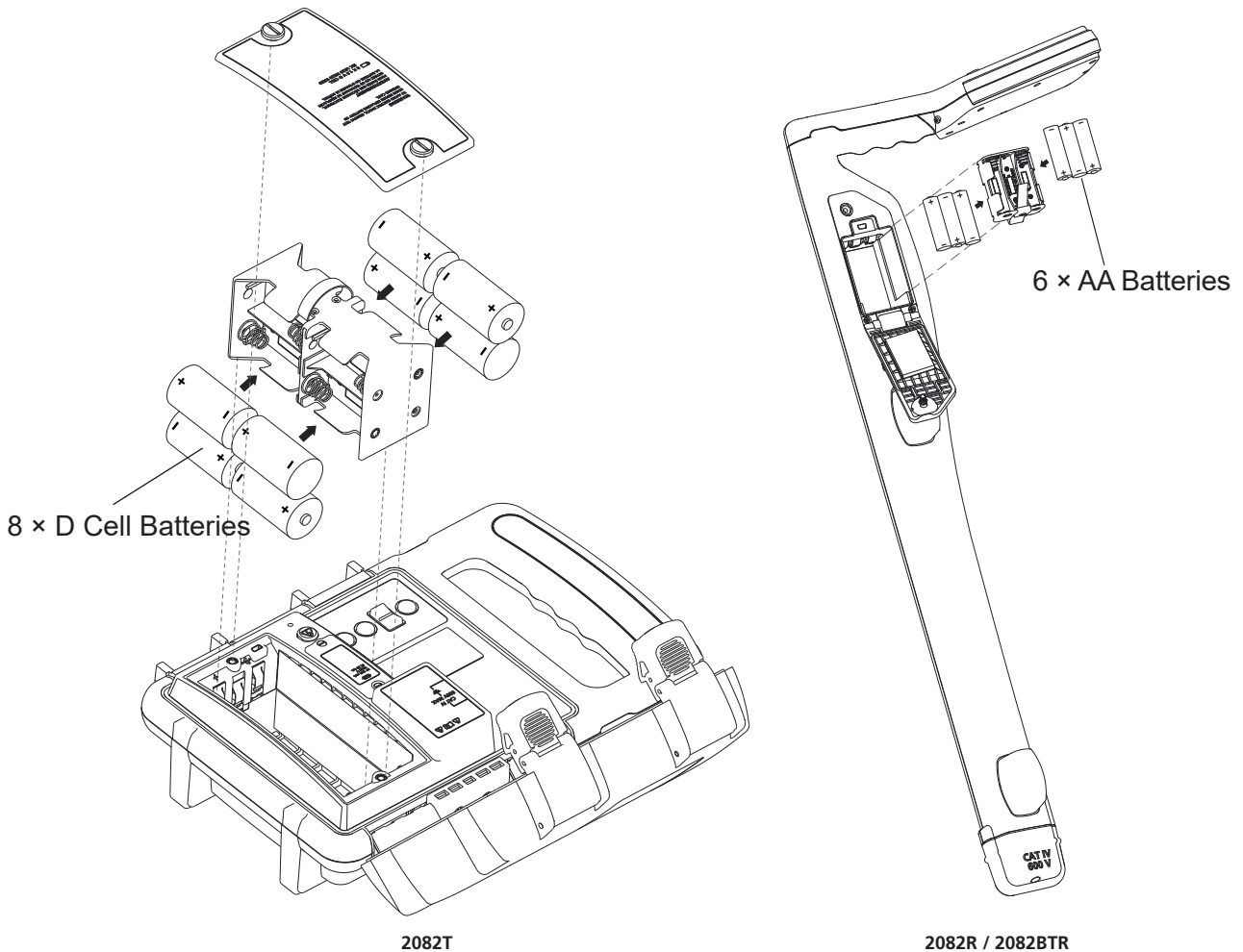

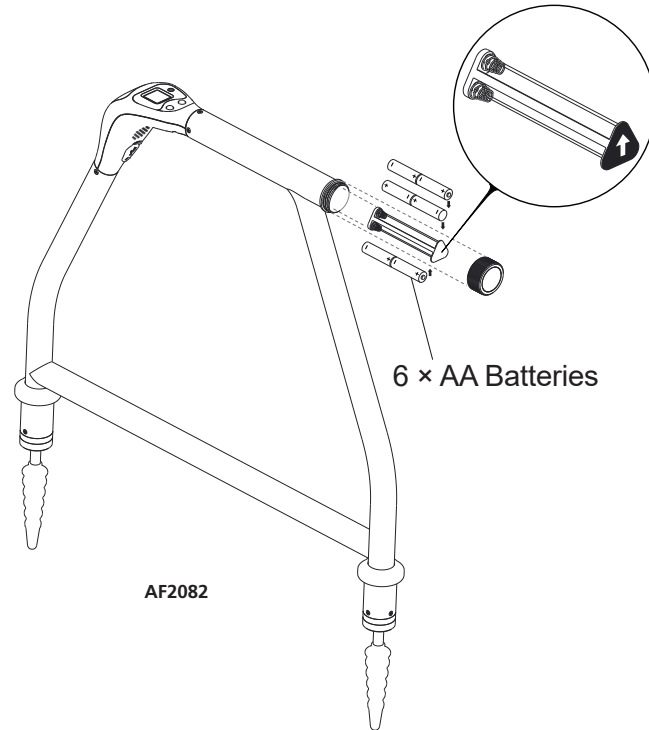

Fuse Replacement

Use a flat screw driver to open the fuse door.

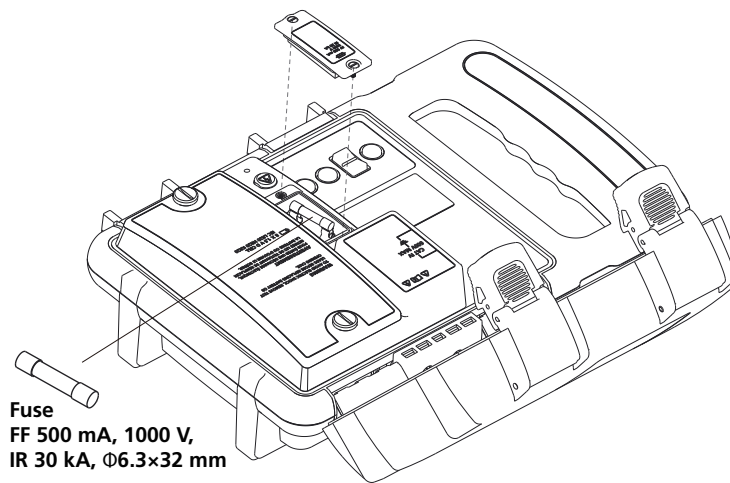

⚠ Use only exact fuse replacement.

Product Disposal

Dispose of the Product in a professional and environmentally sound manner:

- Delete personal data on the Product before disposal.
- Remove batteries that are not integrated into the electrical system before disposal and dispose of batteries separately.
- If this Product has an integral battery, put the entire Product in the electrical waste.